



Leman Instruments

MULTIPOINTS DOUBLE CHANNEL PERMEATION CALIBRATOR



AIR PERMEATION

APPLICATIONS

- ✓ Air Quality Monitors calibration by permeation tube

DESCRIPTION

LEMAN-Instruments designed the modular **Multipoint Double Channel Permeation Calibrator (MP2C)** product line, to fit almost any type of application which needs two lines of high precision gas mixture based on permeation tubes.

FUNCTIONING PRINCIPLE (for each line)

To keep in equilibrium the permeation tube, the oven's temperature is regulated at $\pm 0.05^\circ\text{C}$ and is under a constant flow (50 to 80 ml/min) of Zero Air regulated by Mass Flow Controller 1 (MFC1, MFC3). Between calibrations, the high concentration low flow mixture is directed through a 3/2 valve (V1 or V2) to the exhaust outlet. When the calibration is started, V1 or V2 or both is (are) switched on and the high concentration mixture is (are) injected in the carrier flow of Zero Air generated by MFC2.

Based on the three calibration curves of MFC1, MFC2 and MFC3, as well as the certified value of the tube's permeation rate, the integrated microcontroller adjusts the MFC2's outflow to reach the expected final mixture.

In case of lack of carrier gas, eventual malfunctioning of the oven and before the life time end of permeation tube, the internal controller alarms the host system.

Each instrument is equipped with high performance communication interfaces (RS485, USB, Ethernet (option)) to create a very flexible gas network with local or central control.

2 Lines Multipoint Permeation Calibrator

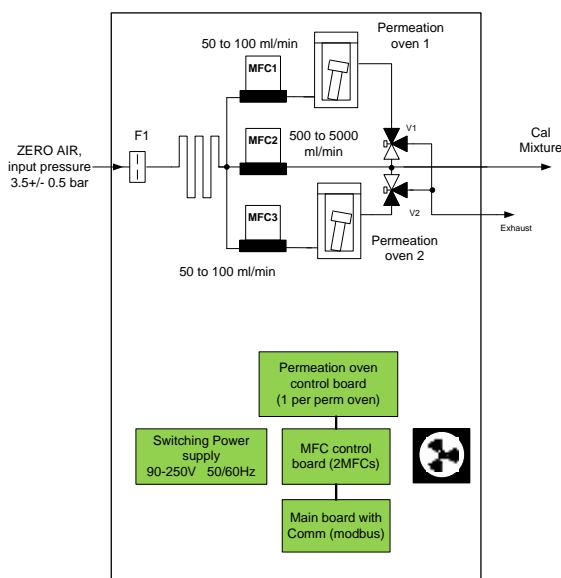

MULTIPOINT DOUBLE CHANNEL

PERMEATION CALIBRATOR

SPECIFICATIONS

Models	MP2C – HC : for Hydrocarbons, BTEX MP2C – ST : for SO ₂ , H ₂ S, NO ₂ , NH ₃ , HCl, ACETALDEHYDE, COS
Outflows @ 1013/20°C	<ul style="list-style-type: none">• 500 to 5000 Nml/min of mixture during calibration• 50 to 80 Nml/min high concentration mixture rest of time
Concentration	<ul style="list-style-type: none">▪ From 10 ppb to 500ppb, depending on the permeation tube
Oven's temperature range	Adjustable by software from 35°C to 80°C, to adjust permeation rate
Oven's temperature stability	Better than +/- 0.05°C
Concentration dynamic	10, by carrier gas flow variation (0.5 L/min to 5 L/min)
Precision of concentration	Better than +/- 1% relative
Repeatability	Better than +/- 0.7% relative
Output Pressure	Atmospheric pressure
Input ZERO AIR quality	High purity ZERO AIR for MP2C-HC : HC & VOC < 0.05ppm, CH ₄ & CO < 0.050ppm for MP2C-ST: NO _x , O ₃ , SO ₂ , H ₂ S, NH ₃ < 1ppb
Input ZERO AIR Pressure	3.5 +/- 0.5 bar relative
ZERO AIR consumption	<ul style="list-style-type: none">• 500 to 5000 Nml/min AIR during calibration phase• 50 to 80 Nml/min AIR rest of time
Control	Through : <ul style="list-style-type: none">■ MODBUS-RTU over RS485, as standard■ Ethernet 10/100 network (option)■ WLAN network, with PC, I-Phone, I-Pad (option)■ Log book download by USB.
Inlet & outlet fittings	Inlets : Stainless steel 1/8" compression Outlets : MP2C – ST : Stainless steel 1/4" compression Outlets : MP2C – HC : PFA 1/4" compression
Materials in contact with mixture	MP2C-HC : Stainless steel MP2C-ST: genuine Teflon and PFA
Power supply	Automatic switching from 90VAC to 260VAC, 47 to 63 Hz
Power consumption	max. 100W
Dimensions	W=483mm/19", H=127mm/5.0ins, D=550mm/22ins
Weight (net)	23.5 Kg

ORDERING NUMBERS

Model	Article #
MP2C-ST	728310
MP2C-HC	728320

Model	Article #
Ethernet Interface option	724181

LEMAN - INSTRUMENTS SAS

Archamps Technopole, 219 rue Laszlo Biro
F – 74160 ARCHAMPS
info@leman-instruments.com

Telephone: +33 4 50 39 49 22

www.leman-instruments.com